



SIMPLICITY IS **INNOVATION**





MAKING A DIFFERENCE IN KITCHENS WORLDWIDE

Your kitchen is constantly balancing the need for efficiency and control with the desire for great-tasting food. For four decades, Eloma has helped chefs and foodservice operators quickly prepare incredible food on a large scale.

Eloma is made for chefs, by chefs. We understand your specific needs because we enlist the help of chefs, bakers, butchers, food technologists and engineers.

With the GENIUS^{MT} and MULTIMAX combi steamers, Eloma once again redefines the way kitchens function. We invite you to get to know our easy-to-use products and learn how they can simplify your cooking and baking processes, reducing stress and boosting productivity across your operation.



THE GENIUS^{MT} IS AT THE HEAD OF ITS CLASS

The GENIUS^{MT} combi steamer provides chefs with unprecedented control, flexibility and support in even the largest and most complex kitchen environments. Its high-resolution display and intuitive controls make it easier than ever to bake, steam, grill and cook at low temperatures or to reheat food.

And, it's all controlled by a touchscreen no more complex than that of a smartphone.



HOOD SPACE

The self-contained condensation hood offers the ultimate advantage.



TOUCHSCREEN

Easy to use, even with wet hands



SHEET PAN

Sized to fit any food tray



LEFT-HINGED DOOR OPTIONS

Designed to fit any cooking space



SIMPLICITY AT ITS BEST

Eloma has designed an intuitive and time-saving control panel with a language-neutral display.

Updates and programs can be utilized more easily than ever before!

WHY CHOOSE OUR MT TECHNOLOGY

SIMPLICITY AT ITS BEST



CUSTOMIZABLE

- **Climatic® MT** allows you to simultaneously set temperature and humidity to an exact degree and percentage.
- Custom picture integration and recipe settings



CONNECTED

- User-friendly management software
- **Remote Communication Access** — Manage your programs & HACCP data via USB or LAN and connect multiple units.



VERSATILE

- 9 cooking methods, 9 menu groups, low-temperature & Delta-T cooking
- 400 cooking and baking programs, plus a favorites function



SAFE

- Fast cool-down function
- Automatic HACCP logbook
- Color-coded guidance with self-explanatory pictograms



SELF-CLEANING

- **autoclean® MT** — Our patented program quick-cleans in 12 minutes, using minimal water and 5 self-cleaning levels.
- Perfect sanitation



FAST

- Cooks most menu items 30%-50% faster than conventional cooking equipment.
- With **Quick Mode**, predetermined operating sequences allow for quick handling.



ENERGY-SAVING

- **Patented Fresh Steam System** — Ready within seconds
- **High-Performance Heat Exchanger** — Allows savings of up to 16% on energy and 42% on water
- **Premix Burner Technology** — Higher energy efficiency, lower exhaust-gas emissions



EASY & CONVENIENT

- **Genuine MultiTouch Technology** — Quick Set option stores all settings exactly as you want them.
- **Memory Function** — Last 20 cooking processes can be seen and restarted, even when manually cooking.
- **Intuitive Operation** — With Multi Cooking, each shelf is individually timed and managed so a variety of items can be cooked at once. Programs can be manually adjusted on the fly.

SMALL SIZE, BIG VOLUME

FULL-SIZED COMBI TECHNOLOGY IN A PINT-SIZED COMBI STEAMER



Eloma combi steamers fit nearly any foodservice environment. Optional configurations include small-footprint units, units with left-hinged doors and stackable units.

The GENIUS^{MT} Compact with condensation hood is shown at left.





LARGE-SCALE OPERATIONS

Equally at home in catering and banqueting operations, hotel room-service settings, hospital environments, and beyond, Eloma combi steamers enjoy the support of a banqueting system designed to enhance their role in high-volume foodservice operations.

The Eloma Banqueting System – racks, rack trolleys and covers, pans, and grids – brings your exquisitely prepared dishes to the masses.



NEW MULTIMAX

The all-new MULTIMAX makes it even easier to prepare exceptional food on a large scale. With personalized cooking programs, automatic heating and cooling functions, and five cleaning programs, you'll have less grime and more time.

On top of all its many features, MULTIMAX is an incredible value. You can get the same capabilities as a high-end combi oven at a price that won't wreck your budget.



HELLO CONTROL

In the kitchen, there is usually no time for long and detailed instructions. That's why we designed an intuitive and time-saving control panel with a language-neutral 5" display and a push-dial. Thanks to the new USB port positioning, updates and programs can be transferred more easily than ever before.



THE SAME AGAIN, PLEASE

It truly assists the chef in day-to-day operations and makes sure that guests are continuously happy with the results. The MULTIMAX memory of 99 programs and the Steptronic® function ensure high-quality results every time.



KITCHEN POSSIBLE

In spite of the simple and basic concept behind it, MULTIMAX remains a multi-talented machine — a true all-rounder! With 7 cooking modes from 86-572° F — proofing, poaching, steaming, retherming, baking, roasting, L-T and Delta -T cooking and regeneration — the MULTIMAX can cover it all.



FULL STEAM AHEAD

The MULTIMAX also features the Eloma Live Steam System. It generates steam directly in the cooking chamber, which is ideal for sensitive food, and also saves you water and energy.

SIMPLY UNCOMPLICATED

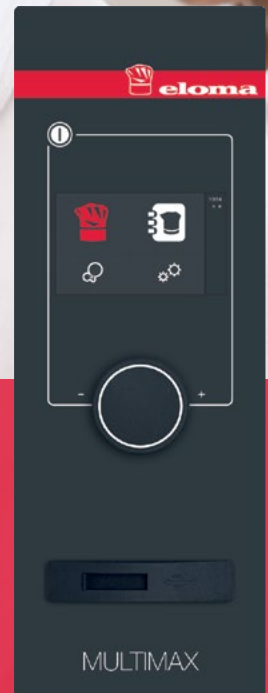

| Icon | Step | Recipe Name | Temp / Humidity | Time | Time |
|------|------|-----------------|-----------------|--------|-------|
| 🔥 | 01 | Roast Beef | h1.45 | | 09:27 |
| 🔥 | 02 | | 86°F / 100% | h03:30 | |
| 🔥 | 03 | LT / Combi | 129°F | | |
| 🔥 | 04 | Delta-T Cooking | 170°F | | |



THE GREEN SIDE

Environmental considerations are an integral part of our philosophy, which Eloma is committed to. From the earliest stages of product design to manufacturing, we take pride in our approach to ensure that our activities and products are environmentally friendly. Our guiding principle is to develop products that will save water and energy, as well as perform more efficiently.



SAVING WATER

The award-winning Eloma Multi-Eco System uses up to 42% less water and up to 16% less energy thanks to its high-performance heat exchanger with condensation. With our Multi-Eco System, Eloma is the only supplier of combi steamers that has been honored with the Dr. Georg Triebe Innovation Award in the category of ecology and efficiency.

SAVING ENERGY

With the ready-to-use Eloma Live Steam System, no preheating or standby mode is required. Compared to a boiler, this significantly reduces energy consumption, saving up to 46%.

ECOLOGICALLY SENSITIVE

The patented Eloma autoclean[®] system delivers a precise dose of liquid cleaner and rinse aid. With precise water-volume management, this eliminates the unnecessary waste of both chemicals and water. The system is fully automated, thus preventing the need for operator contact with the cleaning agent. The Eloma detergent and rinse aid are both kosher certified and biodegradable.

SAVING GAS

The patented high-performance Eloma Triple Pipe-Heat Exchanger ensures, in conjunction with the low-pollution gas burner, perfect energy efficiency while reducing the release of gas emissions and pollutants into the environment.

PATENTED FRESH STEAM SYSTEM®, INVENTED BY ELOMA

- Fresh steam available within seconds
- Perfect steam saturation
- Economical & ecological: short cooking times, greatly reduced energy use & low water consumption

PREMIX-BURNER TECHNOLOGY

- Triple Pipe Heat Exchanger for optimal energy efficiency & lower exhaust-gas emissions into atmosphere
- Long life cycle
- Lower BTUs & lower energy consumption

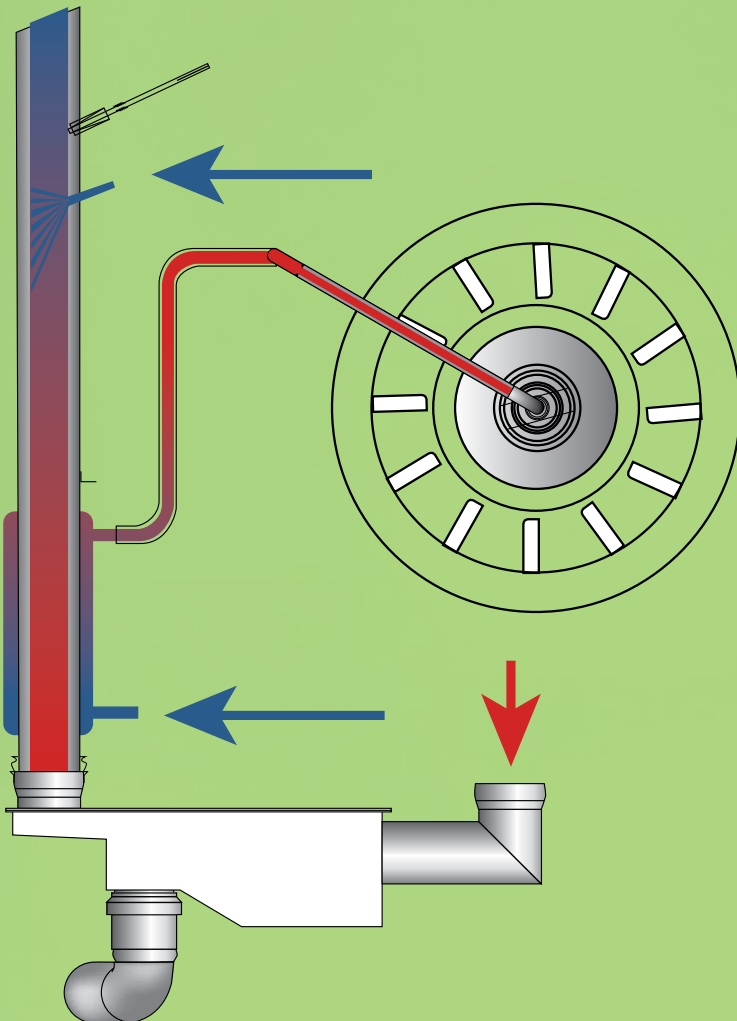

MULTI-ECO SYSTEM

- A high-performance heat exchanger allows savings of up to 16% on energy & up to 42% on water.
- Reduced maintenance costs

PATENTED SPS® STEAM PROTECTION SYSTEM

- Automatic steam extraction in the cooking chamber before completion of the cooking process
- Creates an optimal indoor climate & saves energy

BAKING WITH **LIVE STEAM**

SMOKED SENSATIONS & SOUS VIDE DISHES

Creating smoked meat and flavorful sous vide dishes has never been easier, thanks to Eloma's easy-to-use SmokeFit Smoker and External Core Temperature & Sous Vide Sensor! Designed to deliver delicious smoked meats and flavorful sous vide prepared dishes, these two new products easily expand the menus of restaurant operators and foodservice directors in hospitals, schools, hotels and large corporations.



LIVE STEAM

- Precise, even steaming with dynamic pause times
- Produces pastry products with a perfect sheen and an all-over golden crust



EXTERNAL CORE TEMPERATURE & SOUS VIDE SENSOR

- Monitors temperatures and keeps heat evenly distributed
- Compatible with any GENIUS^{MT} model
- Maintains proper vacuum seal to retain moisture, flavor and nutrients in food



SMOKEFIT SMOKER

- Produces smoke in no time
- Allows food to be simultaneously smoked and cooked
- Stand-alone unit can be used in any Eloma tabletop combi steamer



SPECIFICATIONS



GENIUS^{MT} C 1-1



GENIUS^{MT} /
MULTIMAX 6 - 11



GENERAL DATA

| | | |
|----------------|---|-------------------------------------|
| Trays | 6 half-size sheet pans (18" x 13") or 5 steam table pans (12" x 20") | 6 full-size sheet pans 18" x 26" |
| Capacity | 50-60 meals | 60-100 meals |
| Tray Space | 2.64" | 2.64" |
| W/D/H | 20.5" / 31.7" / 32.8" | 36.42" / 31.69" / 33.07" |
| Banquet System | | |



ELECTRICAL

| | | |
|----------------|-----------------------------|---|
| Weight | 183 lbs. | 287 lbs. |
| Connected Load | 6.4 kW / 8.5 kW | 9 kW |
| Voltage | 208-240 V / 3ph 50/60 Hz | 208 V / 3ph 480 V / 3 ph 50/60 Hz 50/60 Hz |
| Amperage | 25 Amp | 30 Amp 15 Amp |



GAS

| | | |
|----------------|-----------------|-----------------------|
| Weight | ELECTRICAL ONLY | 308.65 lbs. |
| Connected Load | | 1 kW |
| Voltage | | 120 V / 1ph; 50/60 Hz |
| Amperage | | 15 Amp |
| BTUs | | 41,000 |



GENIUS^{MT} /
MULTIMAX 10 - 11



GENIUS^{MT} 12 - 21



GENIUS^{MT} /
MULTIMAX 20 - 21

10 full-size sheet pans
18" x 26"

120-180 meals

2.64"

36.42" / 31.69" / 44.09"

12 full-size sheet pans
18" x 26"

300-480 meals

2.64"

51.57" / 42.76" / 58.66"

60 plates

20 full-size sheet pans
18" x 26"

500-700 meals

2.64"

51.57" / 42.76" / 75.79"

90 plates

369 lbs.

19 kW

208 V / 3ph 480 V / 3 ph

50/60 Hz 50/60 Hz

60 Amp 25 Amp

772 lbs.

22 kW

208 V / 3ph 480 V / 3 ph

50/60 Hz 50/60 Hz

70 Amp 35 Amp

1,092 lbs.

42 kW

208 V / 3ph 480 V / 3 ph

50/60 Hz 50/60 Hz

125 Amp 65 Amp

390 lbs.

1 kW

120 V / 1ph; 50/60 Hz

15 Amp

61,000

805 lbs.

1 kW

120 V / 1ph; 50/60 Hz

15 Amp

119,000

1,168 lbs.

1 kW

120 V / 1ph; 50/60 Hz

15 Amp

239,000

SOLUTIONS

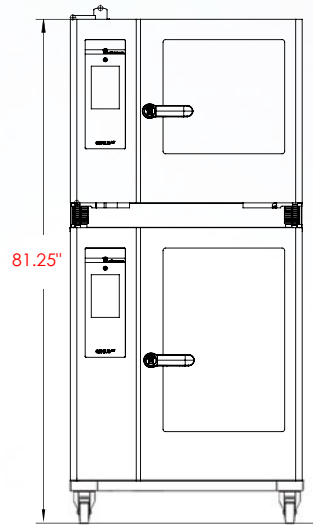

Model 6-11/10-11 Electric
with mobile stand

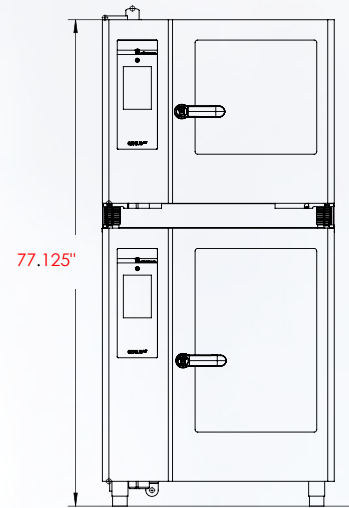

Model 6-11/10-11 Electric
stationary

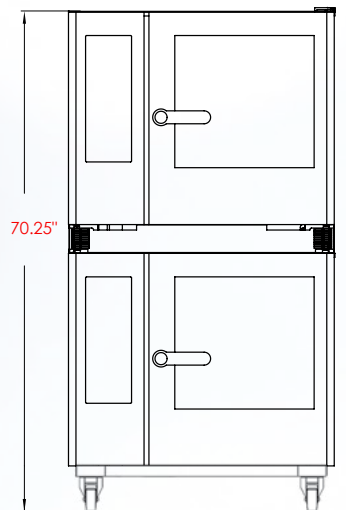

Model 6-11/6-11 Electric
with mobile stand

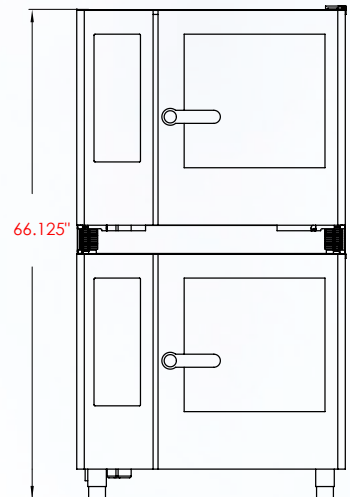

Model 6-11/6-11 Electric
stationary

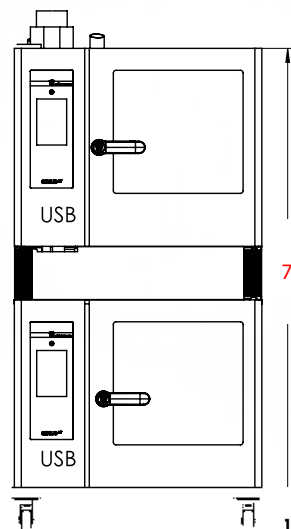

Model 6-11/6-11 Gas
with mobile stand

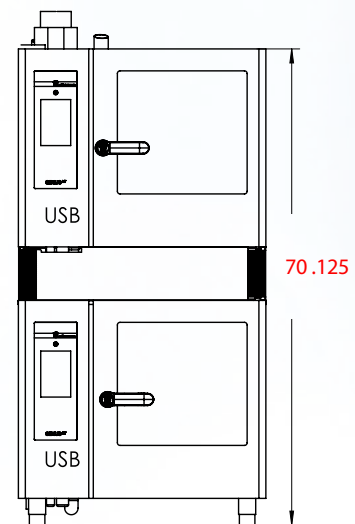

Model 6-11/6-11 Gas
stationary



STACKING SOLUTIONS

All machines are fully compatible with one another, so maximum flexibility is possible with these modular solutions.

MARINE VERSIONS

No matter where you are, our oven technology has been adapted to operate in extreme conditions, so you can use these machines reliably, even on ships and submarines.

RIGHT-OR-LEFT-HINGE DOORS

No matter where you position your machine, Eloma can adapt to suit your requirements.



PUT SOME STEAM IN YOUR TEAM.

Call the Eloma team today to collaborate on a simple, innovative solution for you!

Sales

Phone: 336-201-4946
Toll-free: 844-ELOMAUS (356-6287)
Fax: 336-217-8807
sales@elomausa.com

Service & Support

Hotline: 866-673-7937
Fax: 336-661-1660
service@elomausa.com

elomausa.com

Eloma | 101 Corporate Woods Parkway, Vernon Hills, IL 60061

Eloma Online Tools for Pros



Info 24



Forum



Part Finder



Configurator

an Ali Group Company

