

160 l

KOLBE



AWK130

AUTOMATENWÖLFE AUTOMATIC MINCERS

Technische Daten • Technical Data

Automatenwölfe	Automatic Mincers	AWK130
Schneidsystem	Cutting system	Unger E130
Lochscheibendurchmesser	Perforated plate diameter	mm 130
Trichtervolumen	Funnel volume	Ltr 160
Förderleistung bei 3 mm Lochscheibe ca.*	Hourly throughput with perforated disc of 3 mm approx.*	kg/h 2500
Motorspannung (3Ph)	Motor tension (3Ph)	V 400
Motor - Hauptantrieb / Schutzart IP55 (Optional)	Motor - Main drive / Protection system IP55 (optional)	kW 15 (22)
Motor - Zubringerantrieb / Schutzart IP55	Motor - Feeding drive / Protection system IP55	kW 1,5
Nennstrom bei 400 V - Hauptantrieb	Nominal current at 400 V - Main drive	A 28,5 (40,5)
Nennstrom bei 400 V - Zubringerantrieb	Nominal current at 400 V - Feeding drive	A 3,1
Leiterquerschnitt	Conductor size	mm ² 10 (16)
Netzabsicherung bei 400 V (A träge)	Fusing at 400 V (A lazy)	A 40 (50)
Abmessungen B x T x H	Dimensions W x D x H	mm 1512 x 1386 x 1348
Einfüllhöhe	Input height	mm 1200
Gehäuseauslaufhöhe mit Haube	Lower housing height with cover	mm 512
Lärmpegel	Noise level	dB (A) 70,8
Gewicht netto	Weight net	kg 755 - 800

*Bei Verwendung von einer 3 mm Endlochscheibe, Verarbeitung von kleinen Frischfleischstücken 0 / -1° Grad ohne Zusätze

*hourly throughput with 3 mm final hole plate, processing of small beef or pork pieces 0 / -1° degree without ingredients

AWK130

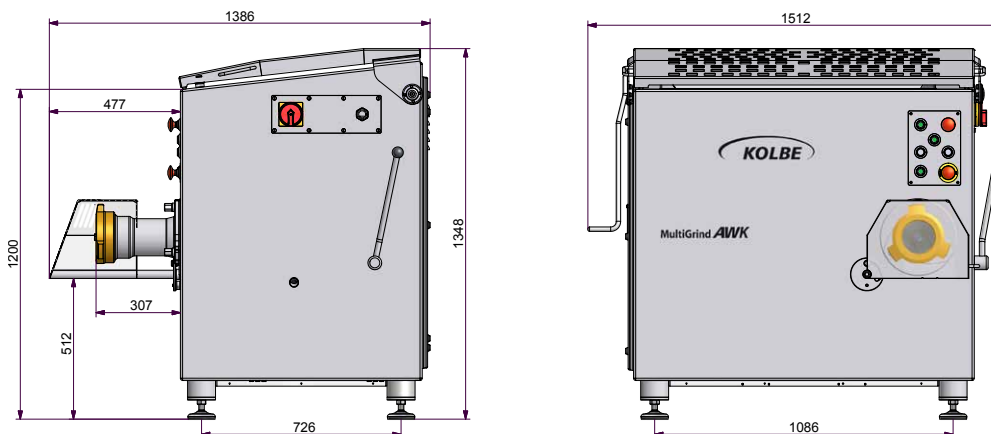

Ausstattungsmerkmale und Vorteile • Features and benefits



Einfache Bedienung
Simple handling



Unger-Schneidwerk
Unger cutting system



Schonender Transport
Ensure gentle transport



Perfekte Hygiene
Perfect sanitary



Paul KOLBE GmbH • FOODTEC

Gewerbestraße 5 • D - 89275 Elchingen

Telefon +49 (0) 73 08 / 96 10 - 0 • Telefax +49 (0) 73 08 / 96 10 - 98

e-mail: info@kolbe-foodtec.com • www.kolbe-foodtec.com