

TOPIC

Cleaning and disinfection machine





The MEIKO *TOPIC* is setting new standards in flawless, economical cleaning and disinfection for care facilities – and offers the highest levels of hygiene and cleanliness for care utensils.

Depending on what is needed in the space, the MEIKO *TOPIC* is available floor mounted or with ground clearance to mount on the wall. We can even provide it as a fully equipped combined care unit, containing everything you may need.

TOPIC stand-alone devices are specially designed to quickly and easily replace out-of-date technology. They are modified to fit into the position of the old appliance, whatever the make of the original – and to use the same connections.

MEIKO does more than manufacture clean solutions. We provide expert consultation and design services. We will work with you to develop an ergonomic utility room design to meet the most demanding requirements of cost-effectiveness, efficiency, health and safety, and hygiene. Bringing all this together, we create a tailored clean solution for you – made by MEIKO.

People take care of people – and MEIKO *TOPIC* takes care of hygiene and cleanliness: that is how care works these days. The innovative *TOPIC* range of machines significantly lightens the workload, freeing up valuable time for the care team to spend with the residents.

TOPIC – The top advantages for you

- Ideal handling with the 'One Touch' operating concept with large membrane keypad and clear symbols
- Hygienic safety due to value A₀ control system to DIN EN ISO 15883
- Very economical thanks to reduced use of operating resources
- Short, individually adjustable and effective programme cycles
- Maximum flexibility due to multifunctional utensil holder concept
- Patented steam-proof cleaning and disinfection system
- Thorough cleaning with power nozzle system
- Electronic control system with diverse cleaning programmes
- Hygiene assurance using thermal disinfection
- Many ways to use thanks to real-world focused options and extensive accessory range

TOPIC means top-of-the-line technology: sturdy MEIKO quality made from non-rusting stainless steel lays the groundwork for durability, easy cleaning and hygiene, making your investment an especially safe bet.

Top: the deep-drawn wash chamber has no corners or tight angles. It is designed to be ideal for self cleaning. The power nozzle system is positioned for the highest efficiency, guaranteeing optimum hygiene for your washware.

Bedpans, urine bottles, commode buckets, etc. are emptied, cleaned and disinfected automatically and reliably. And, of course, always in a sealed environment.

This noticeably reduces the entire care team's workload and they benefit from state-of-the-art convenient hygiene. Even your financial controlling department will be pleased: after all, our reliable and low-maintenance *TOPIC* technology saves resources and budget.

MEIKO TOPIC

State-of-the-art performance and hygiene

TOPIC 10 – For off-the-floor wall mounting (with or without slop sink)

This is the easiest way to install a cleaning and disinfection machine: it saves space and is ready to connect and go.

A practical and compact work unit consisting of the *TOPIC 10* cleaning and disinfection machine and a specially designed slop sink.



Dimensions (in mm)
W 500, D 450 or 588, H (machine) 1,630



Dimensions (in mm)
W 1,000, D 450 or 588, H (machine) 1,630
Splash screen (optional).

TOPIC 20 – Floor-standing units (with or without slop sink)

Floor-mounted cleaning and disinfection machine with plinth: simply position and connect.
Ideal: uses existing connections.

A work unit which is versatile in its functions, easy-to-install and compact. Comprises the floor-mounted *TOPIC 20* cleaning and disinfection machine with a specially designed slop sink.



Dimensions (in mm)
W 500, D 450 or 588, H 1,730



Dimensions (in mm)
W 1,000, D 450 or 588, H 1,730
Splash screen (optional).

MEIKO TOPIC

Exceptional performance in the smallest utility rooms

TOPIC 40 – The practical tabletop model

The *TOPIC 40* cleaning and disinfection machine is the perfect complement to the existing cabinet system. The appliance has a large work and storage surface. Equipped as standard with a lockable storage cabinet for chemical containers.

Tabletop available with upstand for an additional charge.

The *TOPIC 40* cleaning and disinfection machine with built-in hand wash basin and small storage surface is just right as a small, versatile combined work unit.

Equipped as standard with a lockable storage cabinet for chemical containers.

Tabletop available with upstand for an additional charge.



Dimensions (in mm)
Machine
W 900, D 600, H 900



Dimensions (in mm)
Machine
W 900, D 600, H 1,000
Hand wash basin
W 340, D 370, H 150

MEIKO SAN – Combined care unit to fit any space

Cast from the same material: this is the philosophy of MEIKO SAN. Brilliant technology in the tiniest spaces – maximum functionality to make day-to-day care work eas-

ier. We provide expert advice on what combined care unit will best fit your space. Take advantage of our experience of over 90 years – and use the breadth of our *TOPIC* range.

SAN 14 B – TOPIC 40 with slop sink and hand wash basin

Dimensions (in mm):	W 1,400, D 600, H 1,000
Slop sink:	H 700
Slop sink basin:	dia. 364 mm
Hand wash basin:	W 340, D 370, H 150

With lockable storage cabinet for chemical containers (standard)
Splash screen (optional).



SAN 19 B – TOPIC 40 with slop sink, hand wash basin and cabinet, 500 mm

Dimensions (in mm):	W 1,900, D 600, H 900
Slop sink:	H 700
Slop sink basin:	dia. 364 mm
Hand wash basin:	W 340, D 370, H 150
Cabinet space:	W 500

With lockable storage cabinet for chemical containers (standard)
Splash screen (optional).



SAN 20 BW – TOPIC 40 with slop sink, hand wash basin, wash basin and cabinet, 600 mm

Dimensions (in mm):	W 2,000, D 600, H 1,000
Slop sink:	H 700
Slop sink basin:	dia. 364 mm
Hand wash basin:	W 340, D 370, H 150
Wash basin:	W 500, D 400, H 300
Cabinet space:	W 600

With lockable storage cabinet for chemical containers (standard)
Splash screen (optional).



SAN 24 W – TOPIC 40 with slop sink, wash basin and cabinet, 1,000 mm

Dimensions (in mm):	W 2,400, D 600, H 900
Slop sink:	H 700
Slop sink basin:	dia. 364 mm
Wash basin:	W 500, D 400, H 300
Cabinet space:	W 1,000

With lockable storage cabinet for chemical containers (standard)
Splash screen (optional).



SAN 29 BW – TOPIC 40 with slop sink, hand wash basin and cabinet, 1,500 mm

Dimensions (in mm):	W 2,900, D 600, H 900
Slop sink:	H 700
Slop sink basin:	dia. 364 mm
Hand wash basin:	W 340, D 370, H 150
Wash basin:	W 500, D 400, H 300
Cabinet space:	W 1,500

With lockable storage cabinet for chemical containers (standard)
Splash screen (optional).



MEIKO TOPIC

Fantastic user friendliness – made by MEIKO

Ease of use is a particular strength of the *TOPIC* cleaning and disinfection machine. Start a cycle, operate the machine and carry out analysis using the *TOPIC*'s convenient membrane key pad.

You can direct the programme effortlessly using our handy *one-touch technology*. Only *TOPIC* can make care so easy and convenient.

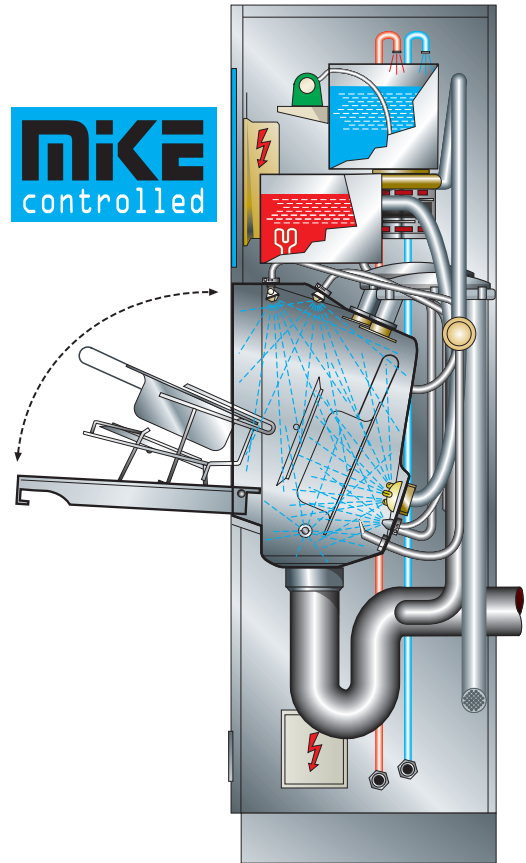
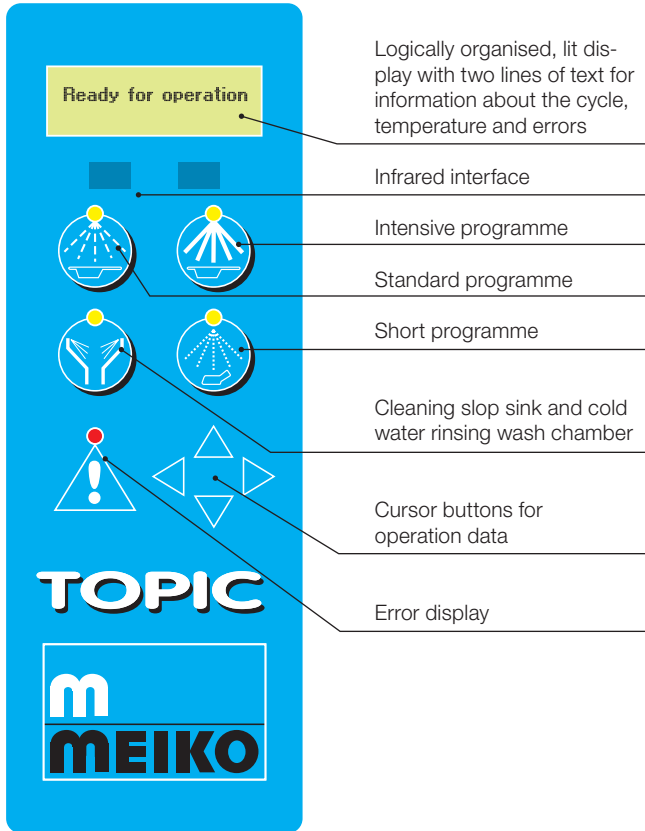

Clean and clear to see:

TOPIC with *M-Commander* service software and extended *M-Commander InVision* (LAN or WLAN) on the analysis software for MEIKO cleaning and disinfection machines.



MEIKO TOPIC Machine upgrades

Cleanliness that know no boundaries

Cleanliness made by MEIKO *TOPIC* knows no boundaries: increase the comfort and performance of your care spaces with several useful system expansions. Our range impresses with many tried-and-tested options. The choice is yours.



TOPIC – Machine upgrades

- **Open and close – touch free (optional)**

Automatic operation of the wash chamber door combines ease of use with maximum safety and security for both patients and staff.

- **Air recooling and drying (optional)**

This *TOPIC* upgrade uses a patented process to cool and dry care utensils with ordinary air. As well as creating a safer and more hygienic workplace, this feature can also save you up to 8 litres of water in each programme cycle. It also ensures that no vapour is released into the room when you open the door at the end of the programme.

- **System disinfection of all pipes carrying water (optional)**

This system uses steam to automatically disinfect the machine after each wash cycle – without incurring any extra operating costs.

MEIKO TOPIC Installations

100 % practical

Whether you go for an individual appliance or a made-to-measure combined care unit: our technology can be adapted to just about any situation. It provides clean solutions that are perfectly tailored to their surroundings. Seamless connections and sealed surfaces to perfectly

connect the individual components are brand distinctives for us. That's how we optimise hygienic utility room work-spaces. The results meet your needs and fulfil all statutory requirements. And our determination to use hygienic materials means that everything is made of stainless steel.

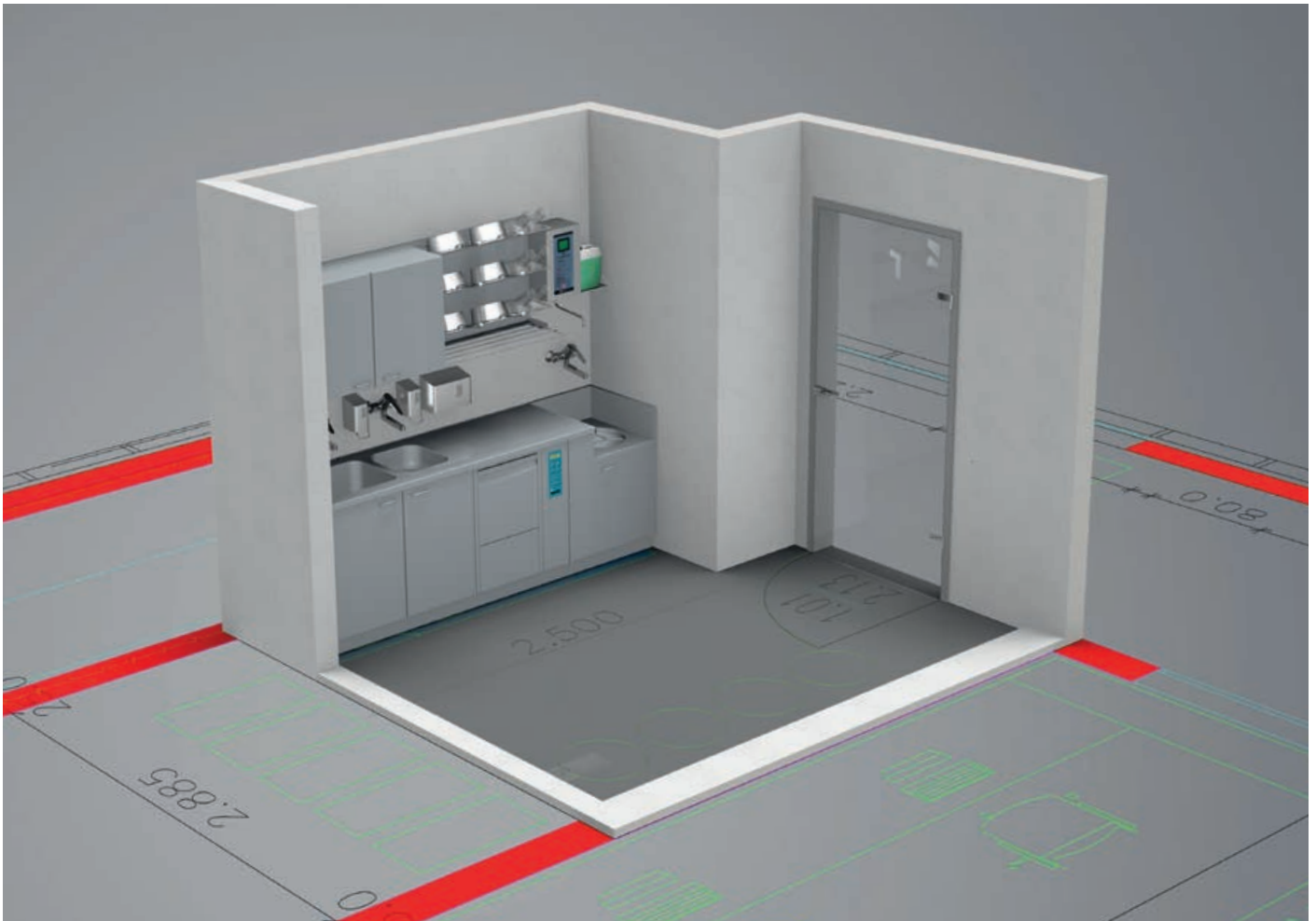

3D dimensional drawing of system

TOPIC floor standing unit

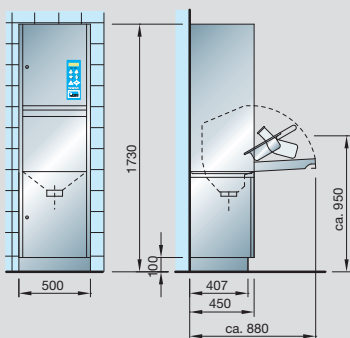

TOPIC small combined care unit

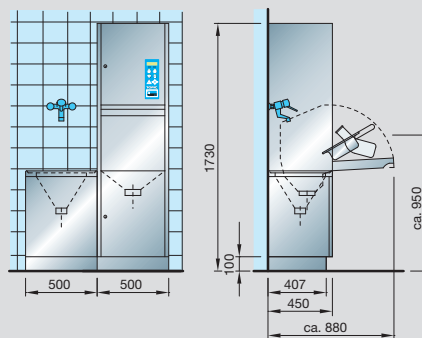

TOPIC unit to go under work surfaces

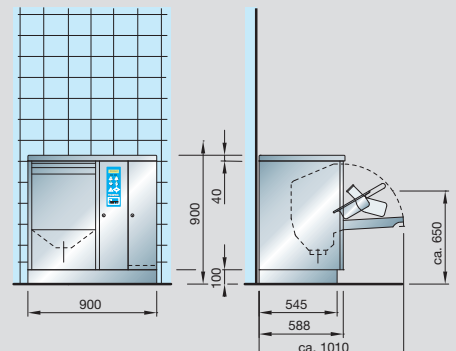

A top choice for care services: MEIKO accessories and modular furnishings

In addition to our MEIKO cleaning and disinfection technology, we also offer a wide range of accessories and furnishings. That means we can guarantee safe and ergonomic work patterns, as well as hygienic storage for your care utensils. We illustrate below 6 examples of practical solutions. We would be happy to develop a range of suggested solutions especially for you. Talk to us! We would be pleased to help you at a moment's notice.



Drying and storage racks*
for disinfected urine bottles, bedpans and receptacles, with storage grid or drip tray. Available in widths of 500 mm to 1400 mm.



Wall shelving*
Rack with height-adjustable shelves available in all shelf lengths. Shelf depth: 350 mm.



Cupboards with doors**
Cupboard units with hinged doors and one intermediate shelf. Available in widths of 500 mm, 600 mm, 800 mm, 1000 mm, 1200 mm and 1500 mm.



Cupboards without doors
Cupboards for easy storage with one intermediate shelf. Available in the following widths: 500 mm, 1000 mm and 1200 mm.



Cleaning combination*
Cupboards for installation under work surfaces (complete with drawers and other facilities) can be designed in a range of widths and heights for combined care units.



Slop sink*
Standard model available as an option with integral rim flushing which can be operated independently of the cleaning and disinfection appliance.

* Pictures contain special equipment

** Optional: lamp shade and lamp



The clean solution



Manufacturer:
MEIKO Maschinenbau GmbH & Co. KG · Englerstr. 3 · 77652 Offenburg, Germany
Phone +49 781 203-0 · Fax +49 781 203-1179
www.meiko-global.com · info@meiko-global.com



760.125.01.11.19/EN/EPP/1000

We reserve the right to make changes
as part of product development.