

# TS

■ Manual Thermosealing machines



**VALKO**<sup>®</sup>



Vacuum packaging technology

Made in Italy

# TS

Mod.

## TS1

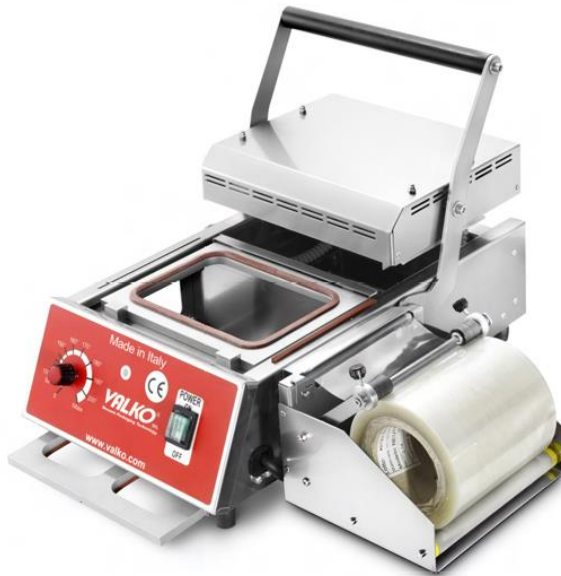

### CHARACTERISTICS

- Built in stainless steel
- Teflon coated aluminium plate
- Electronic control of the plate temperature (0-200°C)
- Housing for a second die
- Manual feed of the roll

Mod.

## TS2



# Optionals



- Demountable cabinet on wheels (with back panel)



- Front door for cabinet



- Intermediate shelf for cabinet

## TECHNICAL INFO

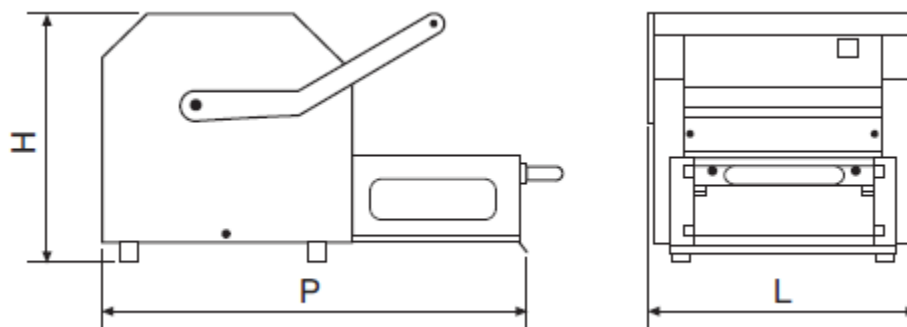

MODEL	WIDTH	DEPTH	HEIGHT	SINGLE IMPRESSION	DOUBLE IMPRESSION	DIE		ROLL	
						MAX. IMPRESSION	MAX HEIGHT OF CUP	WIDTH	MAX DIA.
TS 1	475mm	505mm	355mm	195x140mm	No.2x140x95mm	200x140mm	100mm	150mm	150mm
TS2	515mm	555mm	385mm	195x140mm	No.2x140x95mm	200x180mm	100mm	190mm	200mm